

RC 402 Roof Car

RC 402T

Roof car with telescopic jib extension

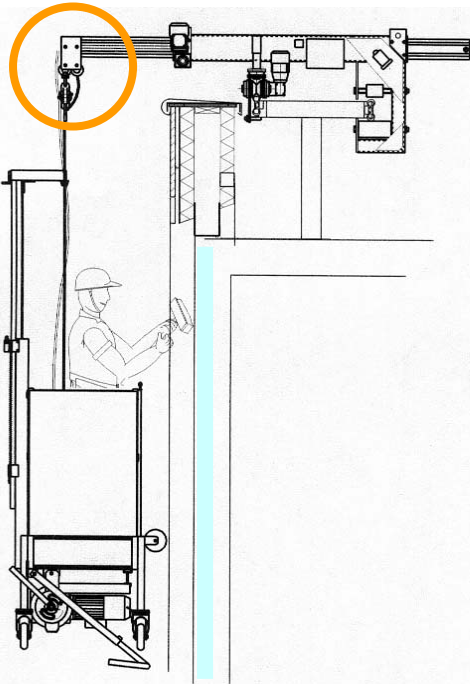

RC 402F

Roof car with traversing trolley jib extension

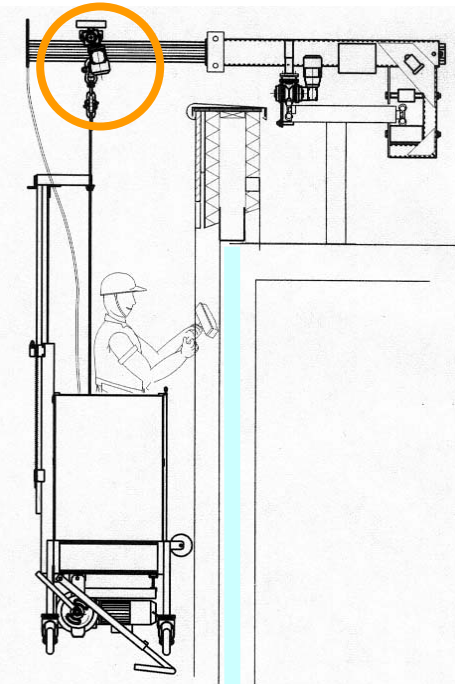

The two-track system is an alternative to the monorail when you wish to hide the rail system. The jib extension makes it possible to come around corners and smaller obstacles on the façade.

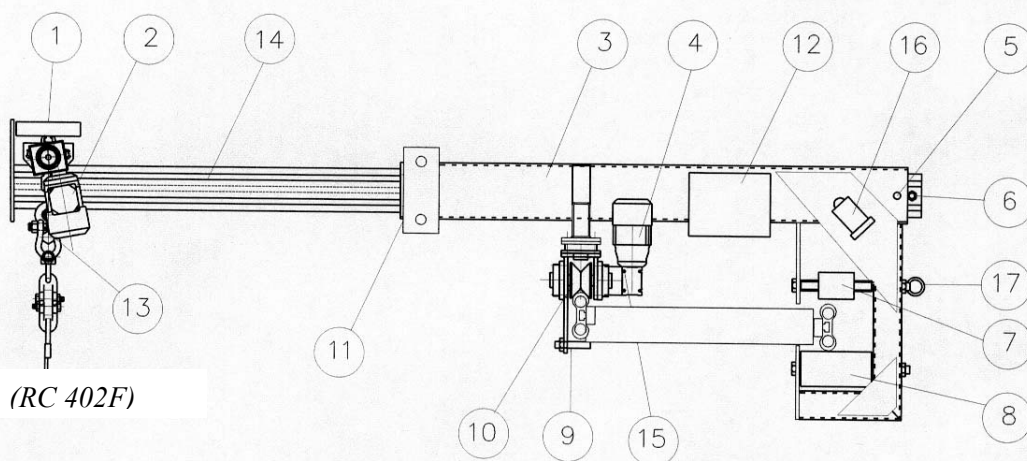

Roof car details

- | | | |
|-----------------------------|----------------------|----------------------------------|
| 1 Jib trolley limit switch | 6 Jib moving pin | 12 Connecting box |
| 2 Jib trolley | 7 Rear support wheel | 13 Wire rope connecting point |
| 3 Chassis | 8 Rear wheel | 14 Jib |
| 4 Sideway traversing motor | 9 Safety pin | 15 Sideway movement limit switch |
| 5 Jib locking pin (RC 402F) | 10 Driving wheel | 16 Power input |
| | 11 Jib support wheel | 17 Supply cable connecting point |